

AIM4065

40mm Diameter

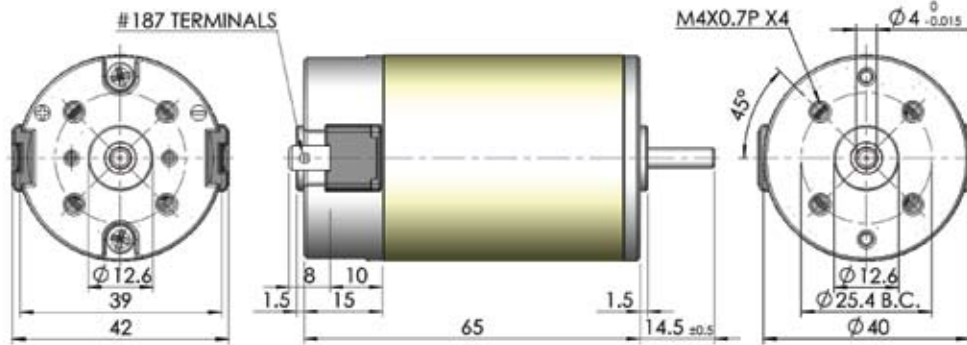

	Volt	No Load			Rated AtMax Eff.				Stall		Peak O/P	Rt	La	Kt	Ke
	VDC	Amps	RPM	oz-in	RPM	Amps	%	Watts	oz-in	Amps	Watts	Ω	mH	oz-in/A	V/K RPM
AIM40659712	12	0.4	1230	1.499	970	1.54	58.06	1.08	7.08	0.58	1.61	20.69	16.9	13.05	9.7
AIM40659724	24	0.43	2420	2.43	2024	2.29	66.21	3.64	14.85	1.18	6.65	20.34	16.9	13.05	9.7
AIM40656312	12	0.62	1800	1.99	1476	2.92	62.29	2.18	11.1	1.34	3.7	8.96	7.25	8.74	6.3
AIM40656324	24	0.68	3750	3.08	3216	4.28	71.34	7.33	21.66	2.6	15.02	9.23	7.25	8.61	6.3
AIM40654512	12	1.02	2550	2.52	2122	5.11	64.7	3.97	15.06	2.54	7.1	4.72	3.77	6.24	4.5
AIM40654524	24	1.1	5200	3.88	4500	7.45	72.34	12.94	28.88	4.83	27.77	4.97	3.77	6.11	4.5
AIM40653812	12	1.06	3000	2.57	2538	6.08	66.12	4.82	16.66	3.36	9.24	3.57	2.7	5.13	3.8
AIM40653824	24	1.22	6100	3.98	5348	9.11	72.12	15.76	32.33	6.52	36.46	3.68	2.7	4.99	3.8
AIM40653312	12	1.3	3500	2.8	2968	7.63	67.23	6.16	18.47	4.3	11.95	2.79	2	4.44	3.3
AIM40653324	24	1.5	7100	4.2	6233	1.119	72.23	19.39	34.44	8.08	45.21	2.97	2	4.3	3.3
AIM40651712	12	3	6500	3.93	5614	2.026	67.11	16.32	28.84	1.297	34.66	0.93	0.54	2.22	1.72

Contact us for more options

ENCODER OPTIONS

AEE3020 ENCODER

DETAILS BELOW

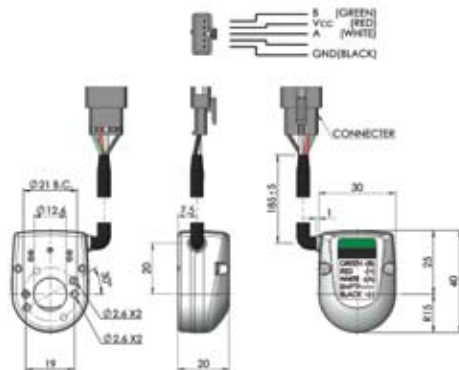

Resolution	3	5	12	16	24	25	50	100	200	256	360	400	500	512	
Power Source	5V~24V			5V±10%			5V±10%								
Current Consumption	≤40mA			≤30mA			≤30mA								
Output Signal	A OR A.B.			A.B.			A.B.								
Indexed				Available											

AEE5500 ENCODER

DETAILS BELOW

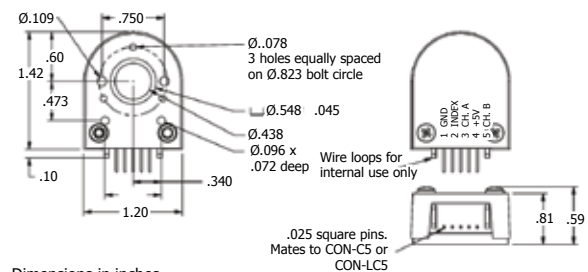

Dimensions in inches

Resolution *	500	1000	2000
Power Source	5V~24V		
Current Consumption	≤40mA		
Output Signal	A OR B		
Indexed	Available		

* Others Available



