

**BL34 SERIES**

MODEL BL3420/GM-036/BI-005/ER-1000/C

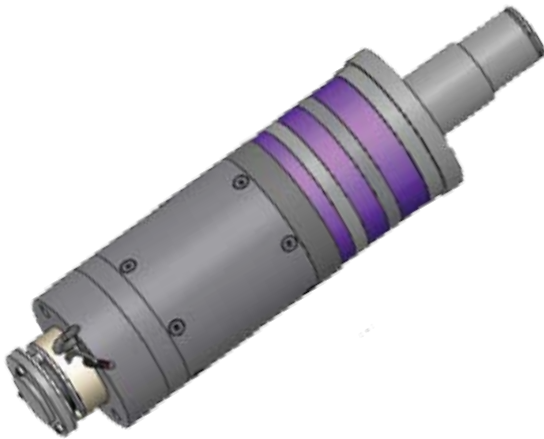

Custom Brushless Gear Motor, planetary gearing, encoder and holding brake designed for leading manufacturer of military robots. Drop in upgrade unit to increase power and speed of robot without chassis modifications. More than double the robots power. Designed, prototyped and delivered within six weeks to meet U.S. Military requirement.

- Turn key Assembly
- Low Profile Commutating Encoder
- 3 Phase Brushless Permanent Magnet
- High Temperature Neodymium Magnets
- Integral Custom Planetary Gearing
- Power Off Brake

**DRAWING**

