

BL34 SERIES

MODEL BL3420/GM-036/BI-005/ER-1000/C

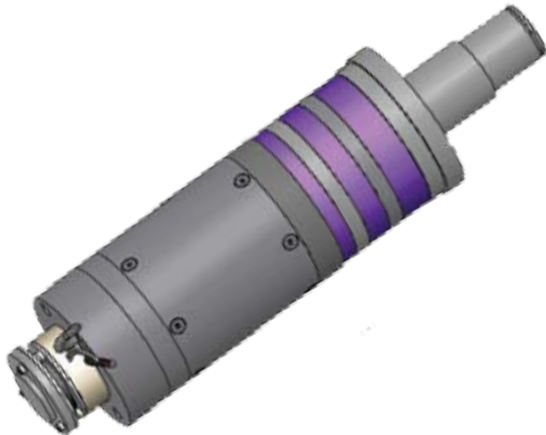

Custom Brushless Gear Motor, planetary gearing, encoder, and holding brake designed for leading manufacturer of military robots. Drop in upgrade unit to increase power and speed of robot without chassis modifications. More than doubled the robots power. Designed, prototyped, and delivered within six weeks to meet U.S. Military requirement.

- Turn key Assembly
- Low Profile Commutating Encoder
- 3 Phase Brushless Permanent Magnet
- High Temperature Neodymium Magnets
- Integral Custom Planetary Gearing
- Power Off Brake

DRAWING

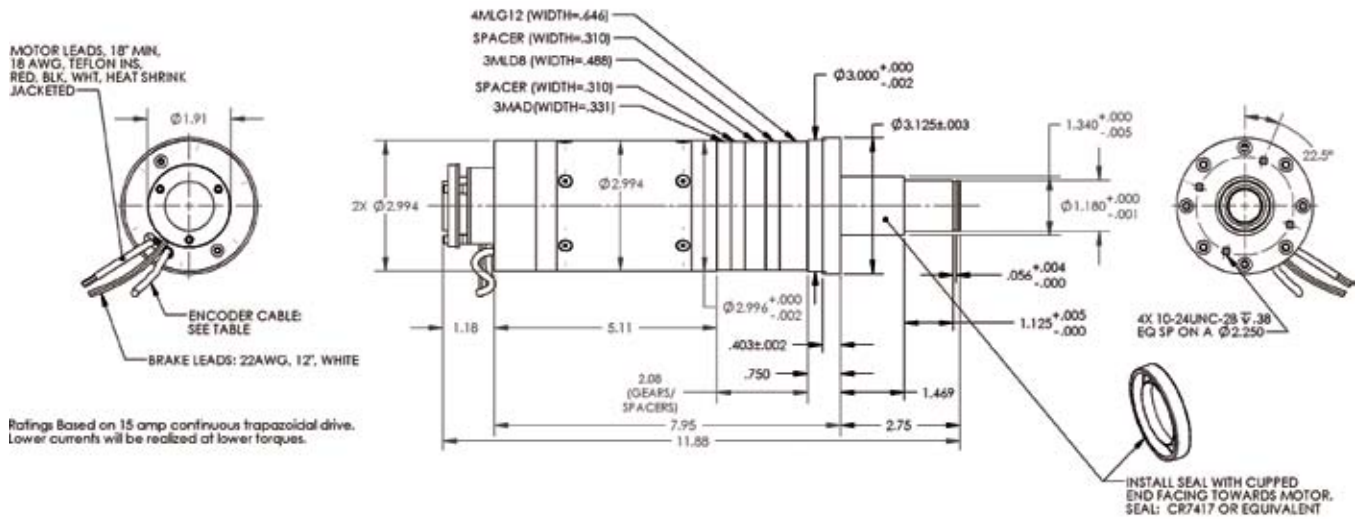

Ratings Based on 15 amp continuous trapezoidal drive. Lower currents will be realized at lower torques.