

## AGN009VPX SERIES

## HIGH QUALITY PLANETARY GEARHEAD

### SPECIFICATIONS:

PART NUMBER	A - Pilot Diameter (in)	B - Square Flange (in)	C - Shaft Length (in)	D - Shaft Diameter (in)	E - Pilot Length (in)	F - Flange Thickness (in)
017VPX	0.866	1.70	0.75	0.500	0.06	0.190
023VPX	1.500	2.25	1.00	0.500	0.06	0.250
034VPX	2.875	3.45	1.25	0.750	0.06	0.312

PART NUMBER	I - Housing Diameter (in)	J - Bolt Hole Diameter (in)	K - Bolt Hole Circle (in)	L1 - GH Length Single Stage (in)	L2 - GH Length Double Stage (in)	Output Shaft Axial Load (Lbs)
017VPX	2.25	0.125	1.725	2.41	2.96	100
023VPX	3.00	0.205	2.625	2.46	3.14	100
034VPX	4.63	0.220	3.875	3.33	4.26	150

Model	Ratio	Torque Rating		Inertia		Radial	Backlash
		T <sub>C</sub> In. Lbs.	T <sub>Peak</sub> In. Lbs.	Input Pinion Oz In Sec <sup>2</sup>	Gear box Oz In Sec <sup>2</sup>	Shaft Loading Lbs.	STD ARC MIN
017VPX	4:1	137	221	1.422E-04	9.095E-05	See	12
017VPX	5:1	130	210	1.293E-04	6.017E-05	Graph	12
017VPX	7:1	113	183	1.246E-04	3.201E-05	Below	12
017VPX	10:1	102	153	1.236E-04	1.591E-05		12
017VPX	15:1	138	224	2.185E-04	1.422E-04		16
017VPX	20:1	151	244	1.293E-04	6.022E-05		16
017VPX	25:1	142	230	1.293E-04	5.848E-05	See	16
017VPX	28:1	153	248	1.246E-04	3.203E-05	Graph	16
017VPX	40:1	156	252	1.236E-04	1.592E-05	Below	16
017VPX	50:1	147	237	1.236E-04	1.549E-05		16
017VPX	70:1	127	205	1.236E-04	1.516E-05		16
017VPX	100:1	102	153	1.236E-04	1.499E-05		16
023VPX	4:1	253	409	1.067E-03	2.544E-04	See	12
023VPX	5:1	248	400	1.033E-03	1.687E-04	Graph	12
023VPX	7:1	201	325	1.020E-03	9.002E-05	Below	12
023VPX	10:1	177	265	1.018E-03	4.305E-05		12
023VPX	15:1	265	428	1.271E-03	4.844E-04		16
023VPX	20:1	279	451	1.033E-03	1.752E-04		16
023VPX	25:1	272	440	1.033E-03	1.705E-04	See	16
023VPX	28:1	284	459	1.020E-03	9.332E-05	Graph	16
023VPX	40:1	289	467	1.018E-03	4.467E-05	Below	16
023VPX	50:1	281	454	1.018E-03	4.249E-05		16
023VPX	70:1	226	366	1.018E-03	4.258E-05		16
023VPX	100:1	177	265	1.018E-03	4.209E-05		16
034VPX	4:1	937	1515	2.393E-03	2.201E-03	See	12
034VPX	5:1	884	1429	2.081E-03	1.463E-03	Graph	12
034VPX	7:1	782	1264	1.965E-03	7.827E-04	Below	12
034VPX	10:1	668	1080	1.942E-03	3.897E-04		12
034VPX	15:1	952	1539	4.247E-03	3.472E-03		16
034VPX	20:1	1046	1690	2.081E-03	1.530E-03		16
034VPX	25:1	980	1585	2.081E-03	1.488E-03	See	16
034VPX	28:1	1065	1721	1.965E-03	8.171E-04	Graph	16
034VPX	40:1	1085	1754	1.942E-03	4.065E-04	Below	16
034VPX	50:1	1016	1642	1.942E-03	3.960E-04		16
034VPX	70:1	889	1437	1.942E-03	3.880E-04		16
034VPX	100:1	753	1217	1.942E-03	3.839E-04		16

PART NUMBER	Efficiency Single Stage	Efficiency Double Stage	Input RPM	Operating Temperature
017VPX	90%	85%	5000	-60°F to +255°F
023VPX	90%	85%	Max.	
034VPX	90%	85%		

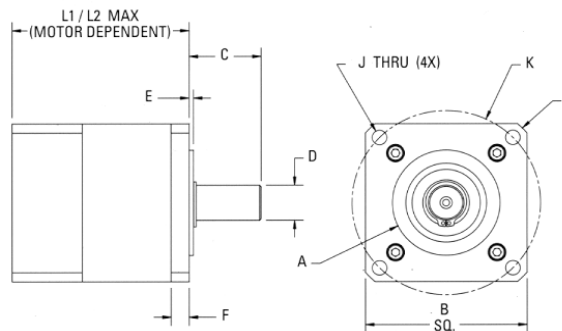
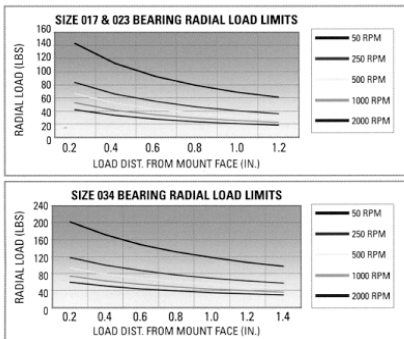

ALL SPECIFICATIONS SUBJECT TO CHANGE.

T<sub>C</sub>: OUTPUT TORQUE IS RATED AT 3000RPM, AND A MINIMUM LIFE OF 10,000 HOURS.

BEARING LOAD RATINGS ARE BASED ON A MINIMUM LIFE OF 10,000 HOURS.